



IDENTIFICATION OF DAMPING: PART 3, SYMMETRY-PRESERVING METHODS

S. ADHIKARI AND J. WOODHOUSE

*Department of Engineering, University of Cambridge, Trumpington Street, Cambridge CB2 1PZ,
England. E-mail: jw12@eng.cam.ac.uk*

(Received 14 May 2001, and in final form 6 September 2001)

In two recent papers (Adhikari and Woodhouse 2001 *Journal of Sound and Vibration* **243**, 43–61; 63–88), methods were proposed to identify viscous and non-viscous damping models for vibrating systems using measured complex frequencies and mode shapes. In many cases, the identified damping matrix becomes asymmetric, a non-physical result. Methods are presented here to identify damping models which preserve symmetry of the system. Both viscous and non-viscous models are considered. The procedure is based on a constrained error minimization approach and uses only experimentally identified complex modes and complex natural frequencies together with, for the non-viscous model, the mass matrix of the system. The methods are illustrated by numerical examples.

© 2002 Elsevier Science Ltd.

1. INTRODUCTION

The nature of damping forces is one of the least understood areas of structural dynamics. In recent papers [1, 2], the authors have proposed methods to identify viscous and certain non-viscous damping models based on measured complex frequencies and mode shapes. Two general conclusions emerge from these studies.

1. Whenever the fitted damping model (whether viscous or non-viscous) is not close to the true damping model of the system, the identified coefficient matrix becomes asymmetric.
2. Once the poles and residues of transfer functions are obtained, several damping models can be fitted equally accurately. In other words, more than one damping model can reproduce a given measured set of transfer functions.

An asymmetric fitted damping matrix is a non-physical result: for example, a viscous damping matrix is symmetric from the form of Rayleigh's dissipation function [3] (Chapter 5). Thus, result 1 above may be regarded as an indication of the fact that the selected model is incorrect. On the other hand, result 2 indicates that if one's interest is only in reconstructing the transfer functions within a given frequency band, then it does not matter even if a wrong damping model is assumed. This is a justification of a kind for the widespread use of the viscous damping model. However, if a correct model of the underlying physical mechanism and distribution of damping is required, this is not a sufficient justification. A wrong model is likely to give misleading results, and may not predict correctly the effect of a structural modification. Motivated by these facts, in this paper we consider fitting of viscous and exponential damping models so that symmetry of the fitted model is preserved.

As in the two earlier papers, the analysis in this paper is restricted to linear systems with light damping. The method of damping identification developed in this paper is based on

complex modes of the system. The theory of complex modes in viscously and non-viscously damped systems is briefly discussed in section 2. Based on first order perturbation results, a method for the identification of a symmetry-preserving viscous damping model using complex modes and natural frequencies is outlined in section 3. In section 4, this method is extended to identify the coefficients of an exponential damping model with a single relaxation parameter. The methods are illustrated by numerical examples.

2. THEORY OF COMPLEX MODES

2.1. VISCOUSLY DAMPED SYSTEMS

The equations of motion for free vibration of a viscously damped linear discrete system with N degrees of freedom can be written as (a list of nomenclature is given in Appendix A)

$$\mathbf{M}\ddot{\mathbf{y}}(t) + \mathbf{C}\dot{\mathbf{y}}(t) + \mathbf{K}\mathbf{y}(t) = \mathbf{0}, \quad (1)$$

where \mathbf{M} , \mathbf{C} and \mathbf{K} are the $N \times N$ mass, damping and stiffness matrices, respectively, and $\mathbf{y}(t)$ is the vector of the generalized co-ordinates. The eigenvalues and eigenvectors, denoted by λ_j and \mathbf{z}_j , respectively, are in general complex. Use of first order perturbation theory [3, 4], gives the expressions for the complex eigenvalues and eigenvectors as

$$\lambda_j \approx \pm \omega_j + iC'_{jj}/2 \quad (2)$$

$$\text{and } \mathbf{z}_j \approx \mathbf{x}_j + i \sum_{\substack{k=1 \\ k \neq j}}^N \frac{\omega_j C'_{kj}}{(\omega_j^2 - \omega_k^2)} \mathbf{x}_k, \quad (3)$$

where ω_j and \mathbf{x}_j are the undamped natural frequencies and mass-normalized mode shapes and $C'_{kl} = \mathbf{x}_k^T \mathbf{C} \mathbf{x}_l$ are the elements of the modal damping matrix.

2.2. NON-VISCOUSLY DAMPED SYSTEMS

A general linear damping model can be described by convolution integrals of the generalized co-ordinates over appropriate kernel functions. This leads to the equations of motion of free vibration:

$$\mathbf{M}\ddot{\mathbf{y}}(t) + \int_{-\infty}^t \mathcal{G}(t - \tau) \dot{\mathbf{y}}(\tau) d\tau + \mathbf{K}\mathbf{y}(t) = \mathbf{0}. \quad (4)$$

Here $\mathcal{G}(t)$ is the $N \times N$ matrix of kernel functions. It is also assumed that $\mathcal{G}(t)$ is a symmetric matrix so that reciprocity holds. In the special case when $\mathcal{G}(t) = \mathbf{C}\delta(t)$, where $\delta(t)$ is the Dirac delta function, equation (4) reduces to the equations of motion with viscous damping (1). By using first order perturbation theory again [4], the complex eigenvalues and eigenvectors can be expressed in a way similar to that for viscously damped systems:

$$\lambda_j \approx \pm \omega_j + iG'_{jj}(\pm\omega_j)/2 \quad (5)$$

$$\text{and } \mathbf{z}_j \approx \mathbf{x}_j + i \sum_{\substack{k=1 \\ k \neq j}}^N \frac{\omega_j G'_{kj}(\omega_j)}{(\omega_j^2 - \omega_k^2)} \mathbf{x}_k, \quad (6)$$

where $G'_{kl}(\omega_j) = \mathbf{x}_k^T \mathbf{G}(\omega_j) \mathbf{x}_l$ are the elements of the frequency-dependent damping matrix at the j th natural frequency and $\mathbf{G}(\omega)$ is the Fourier transform $\mathcal{G}(t)$.

3. IDENTIFICATION OF A SYMMETRIC VISCOUS DAMPING MATRIX

3.1. THEORY

In reference [1], a method was proposed to identify a viscous damping matrix from measured complex frequencies and modes by using a Galerkin-type error minimization approach. This method does not guarantee symmetry of the identified damping matrix. In a numerical simulation study, it was observed that in many cases the identified viscous damping matrix becomes asymmetric. This is a non-physical result since the viscous damping matrix by its definition (through the Rayleigh dissipation function) is symmetric. For this reason we now develop a method such that the identified damping matrix is always symmetric. A constrained optimization method based on Lagrange multipliers is used (see, e.g., Chapter 4 of reference [5]).

Consider $\hat{\lambda}_j$ and $\hat{\mathbf{z}}_j$ for all $j = 1, 2, \dots, m$ to be the *measured* complex natural frequencies and modes. Here, $\hat{\mathbf{z}}_j \in \mathbb{C}^N$ where N denotes the number of measurement points on the structure and the number of modes considered in the study is m . In general $m \neq N$, and usually $N \geq m$. Denote the complex modal matrix as

$$\hat{\mathbf{Z}} = [\hat{\mathbf{z}}_1, \hat{\mathbf{z}}_2, \dots, \hat{\mathbf{z}}_m] \in \mathbb{C}^{N \times m}. \quad (7)$$

If the measured complex mode shapes are consistent with a viscous damping model then from equation (2), the real part of each complex natural frequency gives the undamped natural frequency

$$\hat{\omega}_j = \Re(\hat{\lambda}_j). \quad (8)$$

Similarly from equation (3), the real part of the complex modes immediately gives the corresponding undamped modes and the usual mass-orthogonality relationship will be automatically satisfied. Write

$$\hat{\mathbf{Z}} = \hat{\mathbf{U}} + i\hat{\mathbf{V}}, \quad (9)$$

where

$$\hat{\mathbf{U}} = [\hat{\mathbf{u}}_1, \hat{\mathbf{u}}_2, \dots, \hat{\mathbf{u}}_m] \in \mathbb{R}^{N \times m}$$

$$\text{and } \hat{\mathbf{V}} = [\hat{\mathbf{v}}_1, \hat{\mathbf{v}}_2, \dots, \hat{\mathbf{v}}_m] \in \mathbb{R}^{N \times m} \quad (10)$$

are, respectively, the matrices of real and imaginary parts of the measured complex modes. Now in view of equation (3), expand the imaginary part of $\hat{\mathbf{z}}_j$ as a linear combination of $\hat{\mathbf{u}}_k$:

$$\hat{\mathbf{v}}_j = \sum_{k=1}^m B_{kj} \hat{\mathbf{u}}_k \quad \text{where } B_{kj} = \frac{\hat{\omega}_j C'_{kj}}{\hat{\omega}_j^2 - \hat{\omega}_k^2}. \quad (11)$$

The aim now is to calculate the constants B_{kj} so that the error in representing $\hat{\mathbf{v}}_j$ by the above sum is minimized while the resulting damping matrix remains symmetric. Note that the $k = j$ term has been included in the sum, although in equation (3) this term was absent. This is done to simplify the mathematical formulation to be followed, and has no effect on the result. The interest lies in calculating C'_{kj} from B'_{kj} through the relationship given by the second part of the equation (11), which for $k = j$ gives $C'_{kj} = 0$. The diagonal terms C'_{jj} are instead obtained from the imaginary part of the complex natural frequencies:

$$C'_{jj} = 2\Im(\hat{\lambda}_j). \quad (12)$$

For symmetry of the identified damping matrix \mathbf{C} , it is required that \mathbf{C}' is symmetric, that is

$$C'_{kj} = C'_{jk}. \tag{13}$$

Upon using the relationship given by the second part of equation (11), this condition reads as

$$B_{kj} \frac{\hat{\omega}_j^2 - \hat{\omega}_k^2}{\hat{\omega}_j} = B_{jk} \frac{\hat{\omega}_k^2 - \hat{\omega}_j^2}{\hat{\omega}_k}. \tag{14}$$

Simplification of equation (14) yields

$$\frac{B_{kj}}{\hat{\omega}_j} = -\frac{B_{jk}}{\hat{\omega}_k} \quad \text{or} \quad B_{kj}\hat{\omega}_k + B_{jk}\hat{\omega}_j = 0, \quad \forall k \neq j. \tag{15}$$

For further calculation, it is convenient to cast the above set of equations in a matrix form. Consider $\mathbf{B} \in \mathbb{R}^{m \times m}$ to be the matrix of unknown constants B_{kj} and define

$$\hat{\mathbf{\Omega}} = \text{diag}(\hat{\omega}_1, \hat{\omega}_2, \dots, \hat{\omega}_m) \in \mathbb{R}^{m \times m} \tag{16}$$

to be the diagonal matrix of the measured undamped natural frequencies. From equation (15) for all $k, j = 1, 2, \dots, m$ (including $k = j$ for mathematical convenience),

$$\hat{\mathbf{\Omega}}\mathbf{B} + \mathbf{B}^T\hat{\mathbf{\Omega}} = \mathbf{0}. \tag{17}$$

This equation must be satisfied by the matrix \mathbf{B} in order to make the identified viscous damping matrix \mathbf{C} symmetric. The error from representing $\hat{\mathbf{v}}_j$ by the series sum (11) can be expressed as

$$\boldsymbol{\varepsilon}_j = \hat{\mathbf{v}}_j - \sum_{k=1}^m B_{kj}\hat{\mathbf{u}}_k \in \mathbb{R}^N. \tag{18}$$

It is now desired to minimize the above error subject to the constraints given by equation (15). The standard inner product norm of $\boldsymbol{\varepsilon}_j$ is selected to quantify the error. Upon introducing Lagrange multipliers ϕ_{kj} the objective function may be constructed as

$$\chi^2 = \sum_{j=1}^m \boldsymbol{\varepsilon}_j^T \boldsymbol{\varepsilon}_j + \sum_{j=1}^m \sum_{k=1}^m (B_{kj}\hat{\omega}_k + B_{jk}\hat{\omega}_j)\phi_{kj}. \tag{19}$$

To obtain B_{jk} by the error minimization approach set

$$\frac{\partial \chi^2}{\partial B_{rs}} = 0, \quad \forall r, s = 1, \dots, m. \tag{20}$$

On substituting $\boldsymbol{\varepsilon}_j$ from equation (18) one has

$$\begin{aligned} & -2\hat{\mathbf{u}}_r^T \left(\hat{\mathbf{v}}_s - \sum_{k=1}^m B_{ks}\hat{\mathbf{u}}_k \right) + [\phi_{rs} + \phi_{sr}]\hat{\omega}_r = 0 \\ \text{or } & \sum_{k=1}^m (\hat{\mathbf{u}}_r^T \hat{\mathbf{u}}_k) B_{ks} + \frac{1}{2}[\hat{\omega}_r\phi_{rs} + \hat{\omega}_r\phi_{sr}] = \hat{\mathbf{u}}_r^T \hat{\mathbf{v}}_s, \quad \forall r, s = 1, \dots, m. \end{aligned} \tag{21}$$

The above set of equations can be represented in a matrix form as

$$\mathbf{W}\mathbf{B} + \frac{1}{2}[\hat{\mathbf{\Omega}}\mathbf{\Phi} + \hat{\mathbf{\Omega}}\mathbf{\Phi}^T] = \mathbf{D}, \tag{22}$$

where

$$\mathbf{W} = \hat{\mathbf{U}}^T \hat{\mathbf{U}} \in \mathbb{R}^{m \times m}, \quad \mathbf{D} = \hat{\mathbf{U}}^T \hat{\mathbf{V}} \in \mathbb{R}^{m \times m}, \tag{23}$$

and $\Phi \in \mathbb{R}^{m \times m}$ is the matrix of ϕ_{rs} . Note that both \mathbf{B} and Φ are unknown, so there are in total $2m^2$ unknowns. Equation (22) together with the symmetry condition (17) provides $2m^2$ equations. Thus, both \mathbf{B} and Φ can be solved exactly provided that their coefficient matrix is not singular or badly scaled.

Because in this study Φ is not a quantity of interest, it is convenient to eliminate it. Recalling that $\hat{\Omega}$ is a diagonal matrix, and taking the transpose of equation (22) yields

$$\mathbf{B}^T \mathbf{W}^T + \frac{1}{2} [\Phi^T \hat{\Omega} + \Phi \hat{\Omega}] = \mathbf{D}^T. \quad (24)$$

Now postmultiplying equation (22) by $\hat{\Omega}$, premultiplying equation (24) by $\hat{\Omega}$ and subtracting one has

$$\begin{aligned} \mathbf{W} \mathbf{B} \hat{\Omega} + \frac{1}{2} \hat{\Omega} \Phi \hat{\Omega} + \frac{1}{2} \hat{\Omega} \Phi^T \hat{\Omega} - \hat{\Omega} \mathbf{B}^T \mathbf{W}^T + \frac{1}{2} \hat{\Omega} \Phi^T \hat{\Omega} - \frac{1}{2} \hat{\Omega} \Phi \hat{\Omega} &= \mathbf{D} \hat{\Omega} - \hat{\Omega} \mathbf{D}^T \\ \text{or } \mathbf{W} \mathbf{B} \hat{\Omega} - \hat{\Omega} \mathbf{B}^T \mathbf{W}^T &= \mathbf{D} \hat{\Omega} - \hat{\Omega} \mathbf{D}^T. \end{aligned} \quad (25)$$

In this way Φ has been eliminated. However, note that since the above is a rank-deficient system of equations it cannot be used to obtain \mathbf{B} and the symmetry condition (17) must be used. Rearranging equation (17) yields

$$\mathbf{B}^T = -\hat{\Omega} \mathbf{B} \hat{\Omega}^{-1}. \quad (26)$$

Substituting \mathbf{B}^T into equation (25) and premultiplying by $\hat{\Omega}^{-1}$ results in

$$\hat{\Omega}^{-1} \mathbf{W} \mathbf{B} \hat{\Omega} + \hat{\Omega} \mathbf{B} \hat{\Omega}^{-1} \mathbf{W}^T = \hat{\Omega}^{-1} \mathbf{D} \hat{\Omega} - \mathbf{D}^T. \quad (27)$$

Observe from equation (23) that \mathbf{W} is a symmetric matrix. Now denote

$$\mathbf{Q} = \hat{\Omega}^{-1} \mathbf{W} = \hat{\Omega}^{-1} \mathbf{W}^T, \quad \mathbf{P} = \hat{\Omega}^{-1} \mathbf{D} \hat{\Omega} - \mathbf{D}^T. \quad (28)$$

Upon using the above definitions, equation (27) reads as

$$\mathbf{Q} \mathbf{B} \hat{\Omega} + \hat{\Omega} \mathbf{B} \mathbf{Q} = \mathbf{P}. \quad (29)$$

This matrix equation represents a set of m^2 equations and can be solved to obtain \mathbf{B} (m^2 unknowns) uniquely. To ease the solution procedure, define the operation $\text{vec}: \mathbb{R}^{m \times n} \rightarrow \mathbb{R}^{mn}$ which transforms a matrix to a long vector formed by stacking the columns of the matrix in a sequence one below another. It is known that [6] (see p. 25) for any three matrices $\mathbf{A} \in \mathbb{C}^{k \times m}$, $\mathbf{B} \in \mathbb{C}^{m \times n}$, and $\mathbf{C} \in \mathbb{C}^{n \times l}$, then $\text{vec}(\mathbf{ABC}) = (\mathbf{C}^T \otimes \mathbf{A}) \text{vec}(\mathbf{B})$ where \otimes denotes the *Kronecker product*. Using this relationship and taking vec of both sides of equation (29), one obtains

$$\begin{aligned} (\hat{\Omega} \otimes \mathbf{Q}) \text{vec}(\mathbf{B}) + (\mathbf{Q}^T \otimes \hat{\Omega}) \text{vec}(\mathbf{B}) &= \text{vec}(\mathbf{P}) \\ \text{or } [\mathbf{R}] \text{vec}(\mathbf{B}) &= \text{vec}(\mathbf{P}), \end{aligned} \quad (30)$$

where

$$\mathbf{R} = (\hat{\Omega} \otimes \mathbf{Q}) + (\mathbf{Q}^T \otimes \hat{\Omega}) \in \mathbb{R}^{m^2 \times m^2}. \quad (31)$$

Since \mathbf{R} is a square matrix, equation (30) can be solved to obtain

$$\text{vec}(\mathbf{B}) = [\mathbf{R}]^{-1} \text{vec}(\mathbf{P}). \quad (32)$$

From $\text{vec}(\mathbf{B})$, the matrix \mathbf{B} can be easily obtained by the inverse operation. Obtaining \mathbf{B} in such a way will always make the identified damping matrix symmetric. The coefficients of the modal damping matrix can be derived from

$$C'_{kj} = \frac{(\hat{\omega}_j^2 - \hat{\omega}_k^2) B_{kj}}{\hat{\omega}_j}, \quad k \neq j. \quad (33)$$

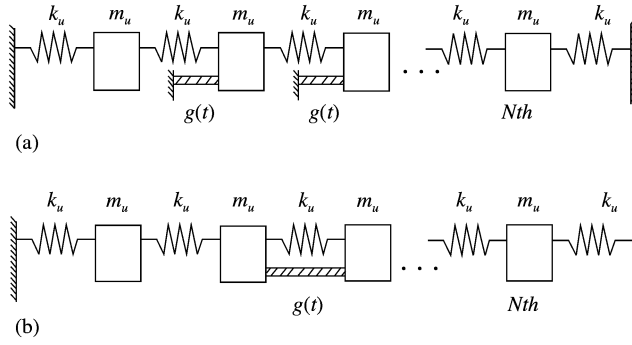

Figure 1. Linear array of N spring-mass oscillators, $N = 30$, $m_u = 1$ kg, $k_u = 4 \times 10^5$ N/m.

The preceding equation can be written in a matrix form as

$$\begin{aligned}
 \mathbf{C}'\hat{\mathbf{\Omega}} &= \mathbf{B}\hat{\mathbf{\Omega}}^2 - \hat{\mathbf{\Omega}}^2\mathbf{B} \\
 \text{or } \mathbf{C}' &= \mathbf{B}\hat{\mathbf{\Omega}} - \hat{\mathbf{\Omega}}^2\mathbf{B}\hat{\mathbf{\Omega}}^{-1}.
 \end{aligned}
 \tag{34}$$

The diagonal terms of \mathbf{C}' , however, must be calculated by using equation (12). Once \mathbf{C}' is obtained, the damping matrix in the original co-ordinates can be obtained by the inverse co-ordinate transformation

$$\mathbf{C} = [(\hat{\mathbf{U}}^T \hat{\mathbf{U}})^{-1} \hat{\mathbf{U}}^T]^T \mathbf{C}' [(\mathbf{U}^T \hat{\mathbf{U}})^{-1} \hat{\mathbf{U}}^T].
 \tag{35}$$

In summary, this procedure can be described by the following steps.

1. Measure a set of transfer functions $H_{ij}(\omega)$ at a set of N grid points. Fix the number of modes to be retained in the study, say m . Determine the complex natural frequencies $\hat{\lambda}_j$ and complex mode shapes $\hat{\mathbf{z}}_j$ from the transfer function, for all $j = 1, \dots, m$. Denote by $\hat{\mathbf{Z}} = [\hat{\mathbf{z}}_1, \hat{\mathbf{z}}_2, \dots, \hat{\mathbf{z}}_m] \in \mathbb{C}^{N \times m}$ the complex mode shape matrix.
2. Set the “undamped natural frequencies” to $\hat{\omega}_j = \Re(\hat{\lambda}_j)$. Denote the diagonal matrix $\hat{\mathbf{\Omega}} = \text{diag}(\hat{\omega}_1, \hat{\omega}_2, \dots, \hat{\omega}_m) \in \mathbb{R}^{m \times m}$.
3. Separate the real and imaginary parts of $\hat{\mathbf{Z}}$ to obtain $\hat{\mathbf{U}} = \Re[\hat{\mathbf{Z}}]$ and $\hat{\mathbf{V}} = \Im[\hat{\mathbf{Z}}]$.
4. From these obtain the $m \times m$ matrices $\mathbf{W} = \hat{\mathbf{U}}^T \hat{\mathbf{U}}$, $\mathbf{D} = \hat{\mathbf{U}}^T \hat{\mathbf{V}}$, $\mathbf{Q} = \hat{\mathbf{\Omega}}^{-1} \mathbf{W}$ and $\mathbf{P} = \hat{\mathbf{\Omega}}^{-1} \mathbf{D} \hat{\mathbf{\Omega}} - \mathbf{D}^T$.
5. Now denote $\mathbf{p} = \text{vec}(\mathbf{P}) \in \mathbb{R}^{m^2}$ and calculate $\mathbf{R} = (\hat{\mathbf{\Omega}} \otimes \mathbf{Q}) + (\mathbf{Q}^T \otimes \hat{\mathbf{\Omega}}) \in \mathbb{R}^{m^2 \times m^2}$.
6. Evaluate $\text{vec}(\mathbf{B}) = [\mathbf{R}]^{-1} \mathbf{p}$ and obtain the matrix \mathbf{B} .
7. From the \mathbf{B} matrix obtain $\mathbf{C}' = \mathbf{B}\hat{\mathbf{\Omega}} - \hat{\mathbf{\Omega}}^2\mathbf{B}\hat{\mathbf{\Omega}}^{-1}$ and $C'_{jj} = 2\Im(\hat{\lambda}_j)$.
8. Finally, carry out the transformation $\mathbf{C} = [(\hat{\mathbf{U}}^T \mathbf{U})^{-1} \hat{\mathbf{U}}^T]^T \mathbf{C}' [(\hat{\mathbf{U}}^T \hat{\mathbf{U}})^{-1} \hat{\mathbf{U}}^T]$ to get the damping matrix in physical co-ordinates.

3.2. NUMERICAL EXAMPLES

Numerical studies have been carried out using simulated systems identical to those used in the earlier papers [1, 2]. Figure 1 shows the model systems together with the numerical values used. The damping elements are associated between the 8th and 17th masses. Damping shown in Figure 1(a) is described as “locally reacting” and that in Figure 1(b) is called “non-locally reacting”. The dissipative elements shown in Figure 1 are taken to be linear non-viscous dampers so that the equations of motion are described by equations (4).

The matrix of the damping functions is considered to be of the form

$$\mathcal{G}(t) = g(t)\mathbf{C}. \quad (36)$$

Two damping models are used as considered in reference [1]: one with an exponential kernel function and the other with a Gaussian kernel function. These models are determined by two different forms of $g(t)$ [defined in equation (36)]:

- MODEL 1 (exponential),

$$g^{(1)}(t) = \mu_1 e^{-\mu_1 t}; \quad (37)$$

- MODEL 2 (Gaussian),

$$g^{(2)}(t) = 2\sqrt{\frac{\mu_2}{\pi}} e^{-\mu_2 t^2}. \quad (38)$$

For both damping models a non-dimensional characteristic time constant is defined as

$$\gamma = \frac{\theta}{T_{min}}, \text{ where } \theta = \int_0^{\infty} t g(t) dt, \quad (39)$$

where T_{min} is the period of the highest undamped natural frequency. As noted in the earlier papers, the value of γ gives a convenient measure of “width”: if it is close to zero the damping behaviour will be near-viscous, and *vice versa*. Complex natural frequencies and modes of the systems, calculated by using equations (5) and (6), are used to apply the identification method developed here.

3.2.1. Results

When γ is small ($\gamma \leq 0.1$) both damping models show near-viscous behaviour. In reference [1] it was shown that for this case the conventionally fitted viscous damping matrix is symmetric. For this reason, results obtained by using the symmetry-preserving identification procedure developed in this paper approach the corresponding results obtained by using the usual procedure.

When γ is larger, the two non-viscous damping models depart from the viscous damping model. For this case, one obtains an asymmetric fitted viscous damping matrix following the procedure in reference [1]. It is interesting to see how these results change when the symmetry-preserving method developed here is applied. Figure 2(a) shows the result of running the symmetry-preserving fitting procedure for damping model 1 with locally reacting damping and the full set of modes. The result of applying the usual viscous damping identification procedure corresponding to this case is shown in Figure 2(b). Upon comparing Figures 2(b) and 2(a) it may be observed that the major features of Figure 2(b), except asymmetry of the damping matrix, reappear in Figure 2(a). From the high non-zero values along the diagonal it is easy to identify the spatial location of the damping. Also observe that all non-zero off-diagonal elements have positive values. This suggests that the damping mechanism may be locally reacting.

In order to understand what result the symmetry-preserving fitting procedure yields when damping is more non-viscous, consider now $\gamma = 2$ for damping model 1. Figure 3(a) shows the fitted viscous damping matrix for the local case. The result corresponding to this without using the symmetry-preserving method is shown in Figure 3(b). Again, from Figure

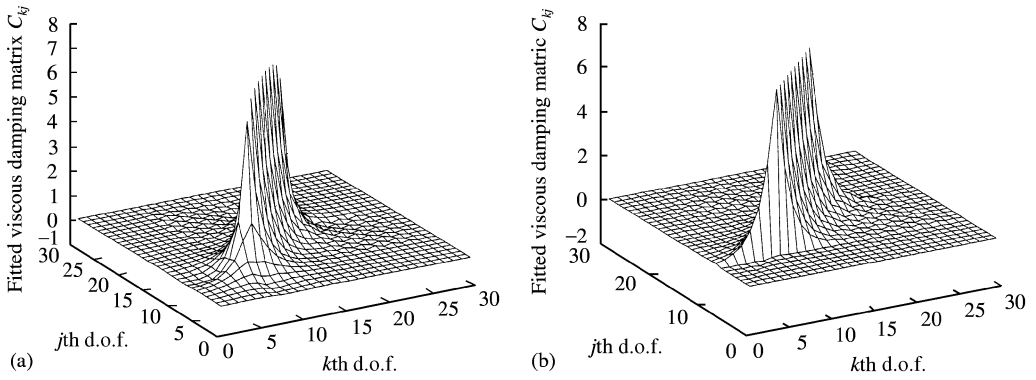

Figure 2. (a) Fitted viscous damping matrix for the local case, $\gamma = 0.5$, damping model 1; (b) fitted viscous damping matrix without using the symmetry-preserving method for the local case, $\gamma = 0.5$, damping model 1.

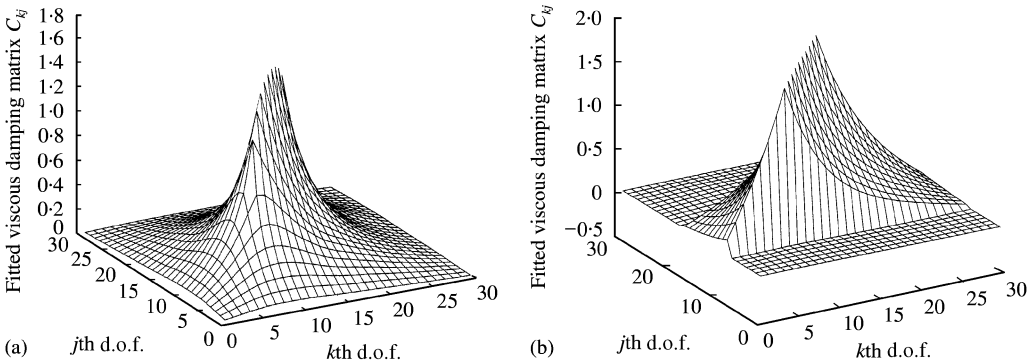

Figure 3. (a) Fitted viscous damping matrix for the local case, $\gamma = 2.0$, damping model 1; (b) fitted viscous damping matrix without using the symmetry-preserving method for the local case, $\gamma = 2.0$, damping model 1.

3(a) the spatial distribution of damping can be guessed, but the accuracy is reduced as the fitted model differs significantly from the actual damping model.

Now consider non-local damping models. Figure 4(a) shows the fitted symmetric viscous damping matrix for $\gamma = 0.5$ using the non-local damping model for damping model 2. The corresponding result obtained without the symmetry-preserving method is shown in Figure 4(b). On comparing these two figures, one clearly observes the improvement of fitting for the case of Figure 4(a). The spatial distribution of the damping is revealed quite clearly and correctly. The non-local nature of the damping is hinted at by the strong negative values on either side of the main diagonal of the matrix.

Because the symmetry-preserving method uses a constrained optimization approach, the numerical accuracy of the fitting procedure might be lower compared to that of the procedure which does not employ the symmetry-preserving method. In order to verify the numerical accuracy, we have reconstructed the transfer functions using the complex modes obtained by using the fitted viscous damping matrix. Comparison between a typical original and reconstructed transfer function $H_{kj}(\omega)$, for $k = 11$ and $j = 24$ is shown in Figure 5, based on locally reacting damping using damping model 1. It is clear that the reconstructed transfer function agrees well with the original one so that there seems no reason to suggest that the new method introduces undue errors.

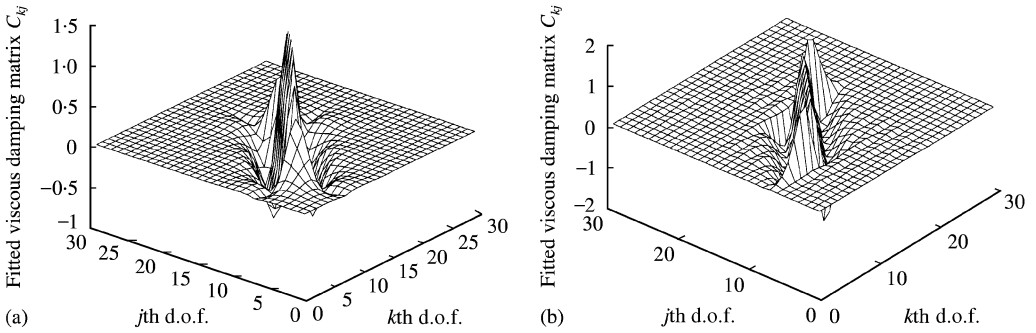

Figure 4. (a) Fitted viscous damping matrix for the non-local case, $\gamma = 0.5$, damping model 2; (b) fitted viscous damping matrix without using the symmetry-preserving method for the non-local case, $\gamma = 0.5$, damping model 2.

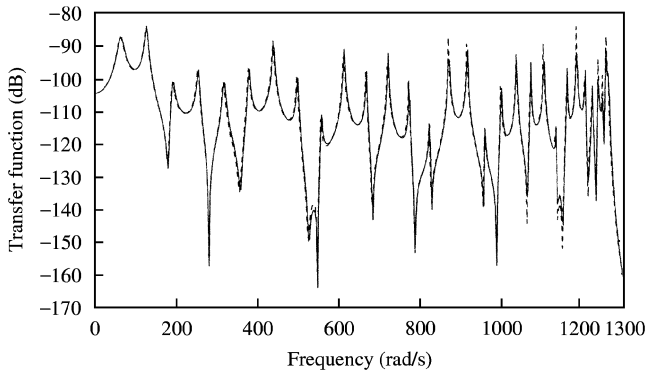

Figure 5. Transfer functions for the local case, $\gamma = 0.5$, damping model 1, $k = 11, j = 24$; (—), exact H_{kj} ; (---), fitted H_{kj} .

4. IDENTIFICATION OF NON-VISCOUS DAMPING

4.1. THEORY

Out of several non-viscous damping models, the exponential function can be argued to be the most plausible [2, 7]. In this section, a method is described to fit an exponential model to measured data such that the resulting coefficient matrix remains symmetric. The mass matrix of the structure is assumed known. Also suppose that the damping has only one relaxation parameter, so that the matrix of the kernel functions is of the form

$$\mathcal{G}(t) = g(t)\mathbf{C}, \text{ where } g(t) = \mu e^{-\mu t}, \tag{40}$$

where μ is the relaxation parameter and \mathbf{C} is the associated coefficient matrix. In reference [2], a method was proposed to obtain μ and \mathbf{C} from measured complex modes and frequencies. This method may yield a \mathbf{C} matrix which is not symmetric. In this section, a method is developed which will always produce a symmetric \mathbf{C} matrix.

Complex natural frequencies and mode shapes for systems with damping of the form (40) can be obtained from equations (5) and (6). In view of the expression for damping given in equation (40), it is easy to see that the term $G'_{kj}(\omega_j)$ appearing in these equations can be expressed as

$$G'_{kj}(\omega_j) = \frac{\mu}{\mu + i\omega_j} C'_{kj} = \left[\frac{\mu^2}{\mu^2 + \omega_j^2} - i \frac{\mu\omega_j}{\mu^2 + \omega_j^2} \right] C'_{kj}. \tag{41}$$

Upon using this expression in equation (5), the j th complex natural frequency is given by

$$\lambda_j \approx \omega_j + i \frac{C'_{jj}}{2} \left[\frac{\mu^2}{\mu^2 + \omega_j^2} - 1 \frac{\mu \omega_j}{\mu^2 + \omega_j^2} \right]. \tag{42}$$

Similarly from equation (6) the j th complex mode can be expressed as

$$\mathbf{z}_j \approx \mathbf{x}_j + \sum_{\substack{k=1 \\ k \neq j}}^N \frac{\mu \omega_j}{(\mu^2 + \omega_j^2)} \frac{\omega_j C'_{kj}}{(\omega_j^2 - \omega_k^2)} \mathbf{x}_k + i \sum_{\substack{k=1 \\ k \neq j}}^N \frac{\mu^2}{(\mu^2 + \omega_j^2)} \frac{\omega_j C'_{kj}}{(\omega_j^2 - \omega_k^2)} \mathbf{x}_k. \tag{43}$$

Assume that

$$\hat{\mathbf{X}} = [\hat{\mathbf{x}}_1, \hat{\mathbf{x}}_2, \dots, \hat{\mathbf{x}}_m] \in \mathbb{R}^{N \times m} \tag{44}$$

is the matrix of undamped mode shapes and $\hat{\mu}$ is the relaxation parameter. In view of equations (43) and (9) and considering that only m modes are measured, separating real and imaginary parts of $\hat{\mathbf{u}}_j$ gives

$$\hat{\mathbf{u}}_j = \Re(\hat{\mathbf{z}}_j) = \hat{\mathbf{x}}_j + \sum_{\substack{k=1 \\ k \neq j}}^m \frac{\hat{\mu} \hat{\omega}_j}{(\hat{\mu}^2 + \hat{\omega}_j^2)} B_{kj} \hat{\mathbf{x}}_k \tag{45}$$

and

$$\hat{\mathbf{v}}_j = \Im(\hat{\mathbf{z}}_j) = \sum_{\substack{k=1 \\ k \neq j}}^m f_j B_{kj} \hat{\mathbf{x}}_k; \text{ where } f_j = \frac{\hat{\mu}^2}{(\hat{\mu}^2 + \hat{\omega}_j^2)}. \tag{46}$$

The unknown constants B_{kj} were defined earlier in equation (11). It may be noted that in addition to B_{kj} , the relaxation constant $\hat{\mu}$ and the undamped modes $\hat{\mathbf{x}}_k$ are also unknown. Combining equations (45) and (46) one can write

$$\hat{\mathbf{x}}_j = \hat{\mathbf{u}}_j - \frac{\hat{\omega}_j}{\hat{\mu}} \hat{\mathbf{v}}_j \quad \forall j = 1, \dots, m, \tag{47}$$

$$\text{or } \hat{\mathbf{X}} = \hat{\mathbf{U}} - \frac{1}{\hat{\mu}} [\hat{\mathbf{V}} \hat{\mathbf{\Omega}}]. \tag{48}$$

The relaxation constant $\hat{\mu}$ has to be calculated from equation (47). By using the orthogonality properties of the eigenvectors it may be shown that

$$\hat{\mu}_j = \frac{\hat{\omega}_j \hat{\mathbf{v}}_j^T \mathbf{M} \hat{\mathbf{v}}_j}{\hat{\mathbf{v}}_j^T \mathbf{M} \hat{\mathbf{u}}_j}. \tag{49}$$

The notation $\hat{\mu}_j$ is used because for different choices of j on the right-hand side one will, in general, obtain different values of $\hat{\mu}$. In reference [2] it was shown that for practical purposes, the value of $\hat{\mu}$ corresponding to the first mode is usually the most appropriate choice.

To ensure symmetry of the identified coefficient matrix condition (13) must hold. For this reason equations (15) and (17) are also applicable for this case. Now, the error from representing $\hat{\mathbf{v}}_j$ by the series sum (46) can be expressed as

$$\boldsymbol{\varepsilon}_j = \hat{\mathbf{v}}_j - \sum_{k=1}^m f_j B_{kj} \hat{\mathbf{x}}_k. \tag{50}$$

This error is to be minimized subject to the constraint in equation (15). The objective function can be formed by using Lagrange multipliers, as was done in equation (19). To obtain the unknown coefficients B_{jk} using equation (20) one has

$$-2\hat{\mathbf{x}}_r^T \left(\hat{\mathbf{v}}_s - \sum_{k=1}^m f_s B_{ks} \hat{\mathbf{x}}_k \right) + [\phi_{rs} + \phi_{sr}] \hat{\omega}_r = 0$$

$$\text{or } \sum_{k=1}^m (\hat{\mathbf{x}}_r^T \hat{\mathbf{x}}_k) f_s B_{ks} + \frac{1}{2} [\hat{\omega}_r \phi_{rs} + \hat{\omega}_r \phi_{sr}] = \hat{\mathbf{x}}_r^T \hat{\mathbf{v}}_s; \forall r, s = 1, \dots, m. \quad (51)$$

The above set of equations can be combined in a matrix form and can be conveniently expressed as

$$\mathbf{W}_1 \mathbf{B} \mathbf{F} + \frac{1}{2} [\hat{\mathbf{\Omega}} \mathbf{\Phi} + \hat{\mathbf{\Omega}} \mathbf{\Phi}^T] = \mathbf{D}_1 \quad (52)$$

in terms of the $m \times m$ matrices

$$\mathbf{W}_1 = \hat{\mathbf{X}}^T \hat{\mathbf{X}}, \quad \mathbf{D}_1 = \hat{\mathbf{X}}^T \hat{\mathbf{V}}, \quad \text{and} \quad \mathbf{F} = \text{diag}(f_1, f_2, \dots, f_m). \quad (53)$$

Equation (52) needs to be solved with the symmetry condition (17). To eliminate $\mathbf{\Phi}$, postmultiplying equation (52) by $\hat{\mathbf{\Omega}}$ and premultiplying its transpose by $\hat{\mathbf{\Omega}}$ and subtracting gives

$$\mathbf{W}_1 \mathbf{B} \mathbf{F} \hat{\mathbf{\Omega}} - \hat{\mathbf{\Omega}} \mathbf{F}^T \mathbf{B}^T \mathbf{W}_1^T = \mathbf{D}_1 \hat{\mathbf{\Omega}} - \hat{\mathbf{\Omega}} \mathbf{D}_1^T. \quad (54)$$

Substitution of \mathbf{B}^T from equation (26) in the above equation and premultiplication by $\hat{\mathbf{\Omega}}^{-1}$ yields

$$\hat{\mathbf{\Omega}}^{-1} \mathbf{W}_1 \mathbf{B} \mathbf{F} \hat{\mathbf{\Omega}} + \mathbf{F}^T \hat{\mathbf{\Omega}} \mathbf{B} \hat{\mathbf{\Omega}}^{-1} \mathbf{W}_1^T = \hat{\mathbf{\Omega}}^{-1} \mathbf{D}_1 \hat{\mathbf{\Omega}} - \mathbf{D}_1^T. \quad (55)$$

Observe from equation (53) that \mathbf{W}_1 is a symmetric matrix and \mathbf{F} is a diagonal matrix. Now denote

$$\mathbf{Q}_1 = \hat{\mathbf{\Omega}}^{-1} \mathbf{W}_1 = \hat{\mathbf{\Omega}}^{-1} \mathbf{W}_1^T, \quad \mathbf{P}_1 = \hat{\mathbf{\Omega}}^{-1} \mathbf{D}_1 \hat{\mathbf{\Omega}} - \mathbf{D}_1^T, \quad \mathbf{H} = \mathbf{F} \hat{\mathbf{\Omega}} = \mathbf{F}^T \hat{\mathbf{\Omega}}. \quad (56)$$

Upon using the above definitions, equation (55) reads as

$$\mathbf{Q}_1 \mathbf{B} \mathbf{H} + \mathbf{H} \mathbf{B} \mathbf{Q}_1 = \mathbf{P}_1. \quad (57)$$

This equation is similar to equation (29) obtained for the viscously damped case and can be solved by using a similar procedure of taking vec of both sides. The procedures to be followed after that to obtain the coefficient matrix \mathbf{C} are also closely similar to the viscously damped case. In summary, the method can be implemented by the following steps.

1. Measure a set of transfer functions $H_{ij}(\omega)$ at a set of N grid points. Fix the number of modes to be retained in the study, say m . Determine the complex natural frequencies $\hat{\lambda}_j$ and complex mode shapes $\hat{\mathbf{z}}_j$ from the transfer function, for all $j = 1, \dots, m$. Denote by $\hat{\mathbf{Z}} = [\hat{\mathbf{z}}_1, \hat{\mathbf{z}}_2, \dots, \hat{\mathbf{z}}_m] \in \mathbb{C}^{N \times m}$ the complex mode shape matrix.
2. Set the ‘‘undamped natural frequencies’’ to $\hat{\omega}_j = \Re(\hat{\lambda}_j)$. Denote the diagonal matrix $\hat{\mathbf{\Omega}} = \text{diag}(\hat{\omega}_1, \hat{\omega}_2, \dots, \hat{\omega}_m) \in \mathbb{R}^{m \times m}$.
3. Separate the real and imaginary parts of $\hat{\mathbf{Z}}$ to obtain $\hat{\mathbf{U}} = \Re[\hat{\mathbf{Z}}]$ and $\hat{\mathbf{V}} = \Im[\hat{\mathbf{Z}}]$.
4. Obtain the relaxation parameter $\hat{\mu} = \hat{\omega}_1 \hat{\mathbf{v}}_1^T \mathbf{M} \hat{\mathbf{v}}_1 / \hat{\mathbf{v}}_1^T \mathbf{M} \hat{\mathbf{u}}_1$.
5. Calculate the diagonal matrix $\mathbf{F} = \text{diag}(\hat{\mu}^2 / \hat{\mu}^2 + \hat{\omega}_j^2) \in \mathbb{R}^{m \times m}$.
6. Obtain the ‘‘undamped modal matrix’’ $\hat{\mathbf{X}} = \hat{\mathbf{U}} - (1/\hat{\mu})[\hat{\mathbf{V}} \hat{\mathbf{\Omega}}]$.
7. From these evaluate the $m \times m$ matrices $\mathbf{W}_1 = \hat{\mathbf{X}}^T \hat{\mathbf{X}}$, $\mathbf{D}_1 = \hat{\mathbf{X}}^T \hat{\mathbf{V}}$, $\mathbf{Q}_1 = \hat{\mathbf{\Omega}}^{-1} \mathbf{W}_1$, $\mathbf{P}_1 = \hat{\mathbf{\Omega}}^{-1} \mathbf{D}_1 \hat{\mathbf{\Omega}} - \mathbf{D}_1^T$ and $\mathbf{H} = \mathbf{F} \hat{\mathbf{\Omega}}$.
8. Now denote $\mathbf{p}_1 = \text{vec}(\mathbf{P}_1) \in \mathbb{R}^{m^2}$ and calculate $\mathbf{R}_1 = (\mathbf{H} \otimes \mathbf{Q}_1) + (\mathbf{Q}_1^T \otimes \mathbf{H}) \in \mathbb{R}^{m^2 \times m^2}$.

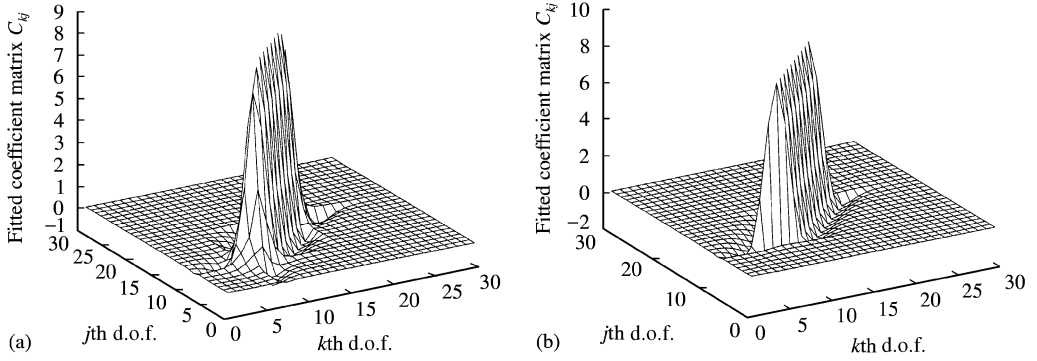

Figure 6. (a) Fitted coefficient matrix of exponential model for the local case, $\gamma = 0.5$, damping model 2; (b) fitted coefficient matrix of the exponential model without using the symmetry-preserving method for the local case, $\gamma = 0.5$, damping model 2.

9. Evaluate $\text{vec}(\mathbf{B}) = [\mathbf{R}_I]^{-1} \mathbf{p}_I$ and obtain the matrix \mathbf{B} .
10. From the \mathbf{B} matrix obtain $C'_{kj} = (\hat{\omega}_j^2 - \hat{\omega}_k^2) B_{kj} / \hat{\omega}_j$ for $k \neq j$ and $C'_{jj} = 2\Im(\hat{\lambda}_j)$.
11. Finally, carry out the transformation $\mathbf{C} = [(\hat{\mathbf{X}}^T \mathbf{X})^{-1} \hat{\mathbf{X}}^T]^T \mathbf{C}' [(\hat{\mathbf{X}}^T \hat{\mathbf{X}})^{-1} \hat{\mathbf{X}}^T]$ to get the damping matrix in physical co-ordinates.

4.2. NUMERICAL EXAMPLES

The systems shown in Figure 1 are again used to illustrate the symmetry-preserving fitting of exponential damping models as outlined in the last subsection. Two damping models, given by equations (37), (38) are again considered. Recall that the relaxation parameter has to be obtained from equation (49) and the symmetry-preserving method has no effect on this. For this reason here we will discuss only fitting of the coefficient matrix.

4.2.1. Results

It has been mentioned before that when γ is small, the ordinary viscous damping identification method [1] and the symmetry-preserving viscous damping identification method (in section 3) yield the same result. In reference [2] it was further noted that for small values of γ the usual non-viscous and viscous damping identification methods produce similar results. This is because both the non-viscous damping models approach a viscous damping model for small values of γ . Since the viscous damping model is a special case of the exponential damping model, the symmetry-preserving non-viscous damping identification method produces results like the three previous methods for small values of γ , and results need not be shown here.

When γ is larger, the non-exponential damping model departs from the exponential damping model. As in the previous examples, we consider $\gamma = 0.5$. For this case, in reference [2] it was observed that the identification method proposed there results in an asymmetric coefficient matrix. The degree of asymmetry of the fitted coefficients depends on how much the original damping model deviates from the identified exponential model. Specifically, it was concluded that when variation of μ_j with j calculated using equation (49) is large, then the fitted coefficient matrix is likely to be significantly asymmetric. The aim now is to understand how the proposed method overcomes this problem and what one could tell from the identified coefficient matrix about the nature of damping. Figure 6(a) shows the

fitted symmetric coefficient matrix for the local case with damping model 2. The result corresponding to this without using the symmetry-preserving method is shown in Figure 6(b). Comparison of these two figures demonstrates the advantage of the symmetry-preserving method. The identified coefficient matrix is not only symmetric, but also the correct spatial location of damping can be deduced from the peak along the diagonal. As in the viscous case, predominantly positive values of the off-diagonal entries of the fitted coefficient matrix indicate that damping is locally reacting. No significant degradation in resolution has occurred as a consequence of the symmetry constraint.

5. CONCLUSIONS

In this paper, a method has been proposed to preserve symmetry of an identified damping matrix. Both viscous and non-viscous damping models were considered. For fitting a viscous damping model, only complex natural frequencies and mode shapes are required. To fit a non-viscous model, in addition to the modal data, knowledge of the mass matrix is also required. However, availability of the complete set of modal data is not a requirement of these methods. The proposed methods utilize a least-squares error minimization approach together with a set of constraints which guarantee symmetry of the fitted damping matrix. It was shown that, for the cases when application of the usual damping identification methods described in references [1, 2] produces an asymmetric matrix, this method not only fits a symmetric matrix but also preserves all the other useful information about the system's damping properties. If the aim of the analysis is to fit a reasonable model of damping to the behaviour of a given structure, it seems that the symmetry-preserving method should always be used. However, if the object is to find the "correct" damping model, it should be borne in mind that departures from symmetry can give diagnostic information to show when the assumed model is wrong [1, 2]. What has been done here is to sweep that under the carpet, and the method should be used with caution.

ACKNOWLEDGMENT

The first author is grateful to the Nehru Memorial Trust, London and the Cambridge Commonwealth Trust for providing financial support for this research.

REFERENCES

1. S. ADHIKARI and J. WOODHOUSE 2001 *Journal of Sound and Vibration* **243**, 43–61. Identification of damping: part 1, viscous damping.
2. S. ADHIKARI and J. WOODHOUSE 2001 *Journal of Sound and Vibration* **243**, 63–88. Identification of damping: part 2, non-viscous damping.
3. LORD RAYLEIGH 1877 *Theory of Sound* (two volumes). New York: Dover Publications; 1945 re-issue, second edition.
4. J. WOODHOUSE 1998 *Journal of Sound and Vibration* **215**, 547–569. Linear damping models for structural vibration.
5. K. F. RILEY, M. P. HOBSON and S. J. BENICE 1997 *Mathematical Methods for Physics and Engineering*. Cambridge, UK: Cambridge University Press.
6. K. ZHOU, J. C. DOYLE and K. GLOVER 1995 *Robust and Optimal Control*. Upper Saddle River, NJ: Prentice-Hall Inc.
7. L. CREMER and M. HECKL 1973 *Structure-Borne Sound*. Berlin, Germany: Springer-Verlag; second edition translated by E. E. Ungar.

APPENDIX A: NOMENCLATURE

C	viscous damping matrix
$\mathcal{G}(t)$	damping function matrix in the time domain
$g(t)$	non-viscous damping functions
$\mathbf{G}(\omega)$	Fourier transform of damping function matrix $\mathcal{G}(t)$
$\mathbf{G}'(\omega)$	frequency domain damping function matrix in the modal co-ordinates
$H_{ij}(\omega)$	set of measured transfer functions
K	stiffness matrix
M	mass matrix
N	degrees of freedom of the system
m	number of measured modes
t	time
T_{min}	minimum time period for the system
\mathbf{x}_j	j th mass-normalized undamped mode
$\hat{\mathbf{x}}$	j th measured undamped mode
X	matrix containing \mathbf{x}_j
$\mathbf{y}(t)$	vector of the generalized co-ordinates
\mathbf{z}_j	j th complex mode
$\hat{\mathbf{z}}_j$	j th measured complex mode
$\hat{\mathbf{Z}}$	matrix containing $\hat{\mathbf{z}}_j$
$\hat{\mathbf{u}}_j$	real part of $\hat{\mathbf{z}}_j$
$\hat{\mathbf{U}}$	matrix containing $\hat{\mathbf{u}}_j$
$\hat{\mathbf{v}}_j$	imaginary part of $\hat{\mathbf{z}}_j$
$\hat{\mathbf{V}}$	matrix containing $\hat{\mathbf{v}}_j$
ω_j	j th undamped natural frequency
$\mathbf{\Omega}$	diagonal matrix containing ω_j
λ_j	j th complex natural frequency of the system
$\mathbf{\varepsilon}_j$	error vector associated with j th complex mode
χ^2	objective function
ϕ_{rs}	Lagrange multipliers
$\mathbf{\Phi}$	matrix containing ϕ_{rs}
ζ_j	j th modal damping factor
μ	relaxation parameter of the fitted damping model
$\hat{\mu}_j$	estimated relaxation parameter for j th mode
μ_1	constant associated with exponential damping function
μ_2	constant associated with Gaussian damping function
θ	characteristic time constant
γ	non-dimensional characteristic time constant
$\delta(t)$	Dirac delta function
\otimes	Kronecker product
\mathbb{C}	space of complex numbers
\mathbb{R}	space of real numbers
$\Re(\bullet)$	real part of (\bullet)
$\Im(\bullet)$	imaginary part of (\bullet)
(\bullet)	measured value of (\bullet)
$(\bullet)^T$	matrix transpose of (\bullet)
$(\bullet)^{-1}$	matrix inverse of (\bullet)
$(\dot{\bullet})$	derivative of (\bullet) with respect to t